



Packaging materials

*Course: Post-harvest technology and
minimal processing of fruits and vegetables*



Telma Delgado & Maria de Fátima Poças

Packaging Department

Biotechnology College – Portuguese Catholic University

Lisboa, 3 – 5 December 2007



- **Product needs and packaging requirements for minimally processed F&V**
- **Types of packaging**
- **Packaging materials**
- **Active and intelligent packaging**





- **Monitoring and controlling**

- **Temperature**

- Respiration, ethylene production, water loss
 - Respiration rate increases 2-3 times each 10°C increase

- **Handling conditions**

- Mechanical damage accelerates senescence

- **Concentration of gases in the product surroundings**

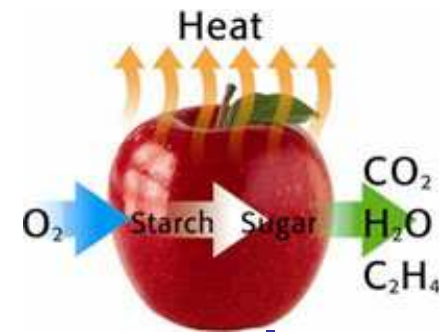



- **Barrier properties**
 - Oxygen, Carbon dioxide
 - Water vapour
 - $\beta = \text{PCO}_2/\text{PO}_2$
 - Variation with temperature
 - **Package format and volume**
 - **Integrity (seals efficiency)**
 - **Optical properties (anti-fogging)**
 - **Material safety and leg. compliance**
 - **Mechanical resistance and handling**

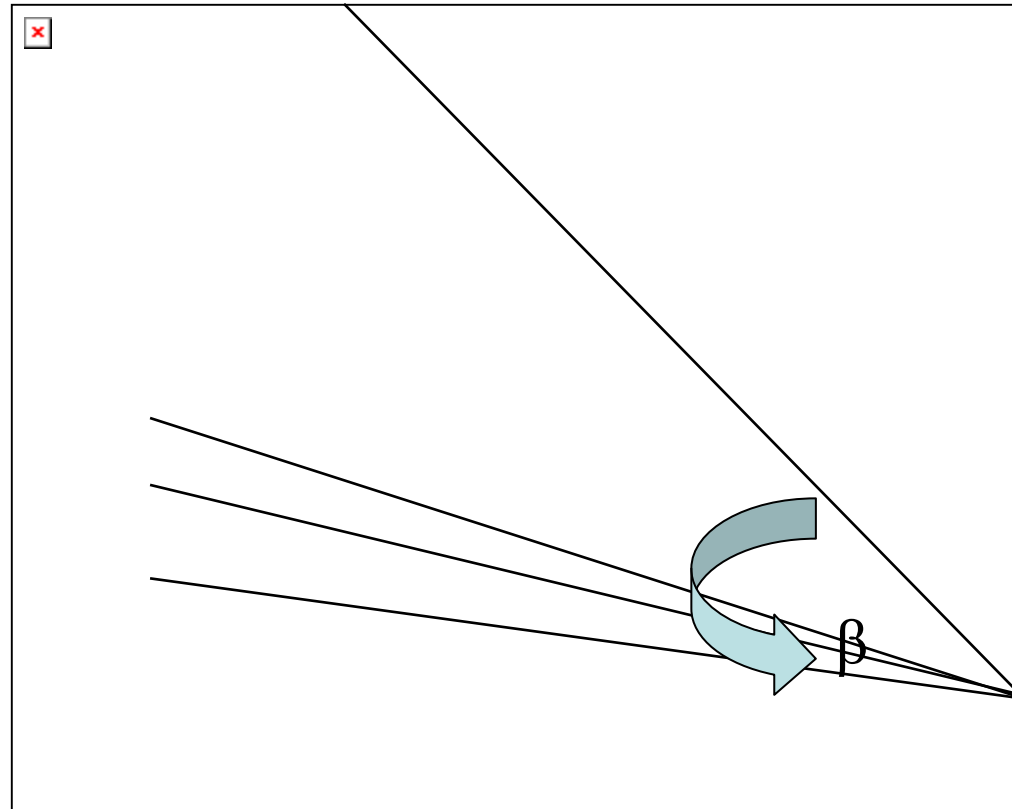

$$C_{DC}(\infty) \approx C_{DC}^{ar} + \frac{1}{\beta} [C_{Ox}^{ar} - C_{Ox}(\infty)]$$



$$C_{DC}(t) = C_{DC}^{ar} + \frac{R_{DC}lW}{P_{DC}A} \left[1 - \exp\left(-\frac{P_{DC}A}{lW}t\right) \right]$$

$$C_{Ox}(t) = C_{Ox}^{ar} - \frac{R_{Ox}lW}{P_{Ox}A} \left[1 - \exp\left(-\frac{P_{Ox}A}{lW}t\right) \right]$$

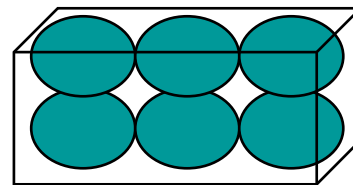
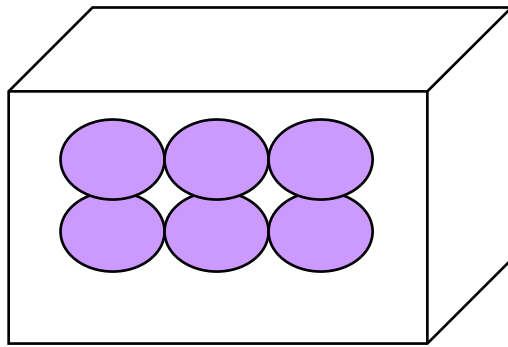



- **Pouch**
- **Tray with lid or inside a pouch**
- **Tray with lid**



- **Machines integrated or not**



- **Vacuum chamber, for pouches**

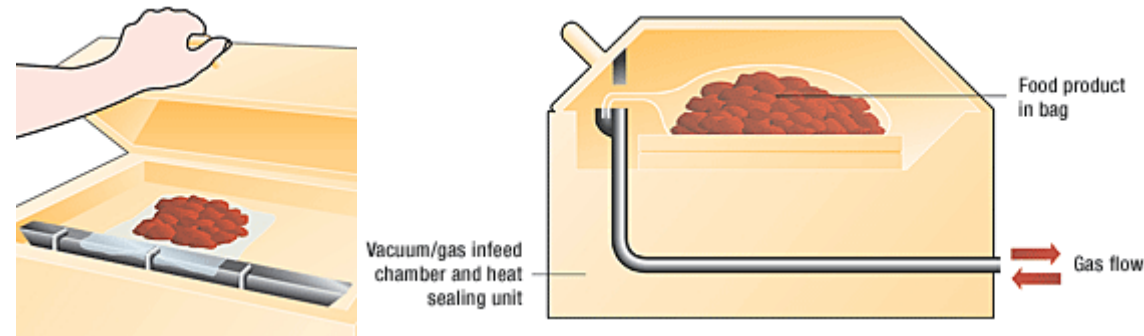

- **Trays inside a pouch**

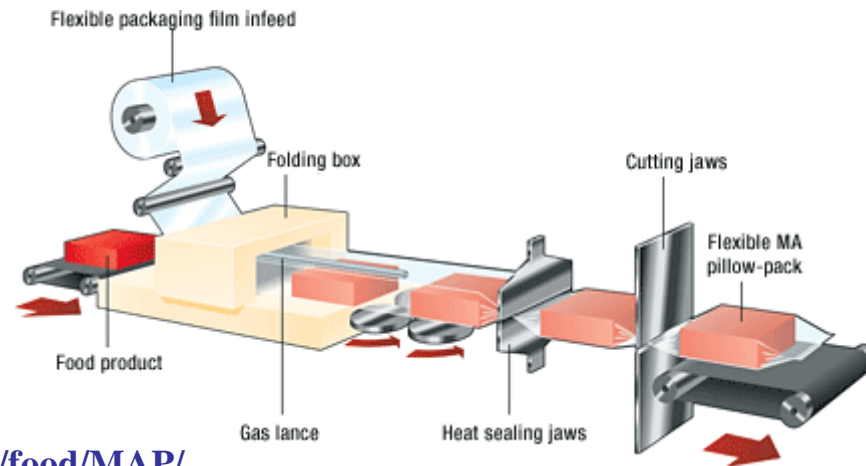



- **Trays and lid**
 - Pre-formed
 - FFS

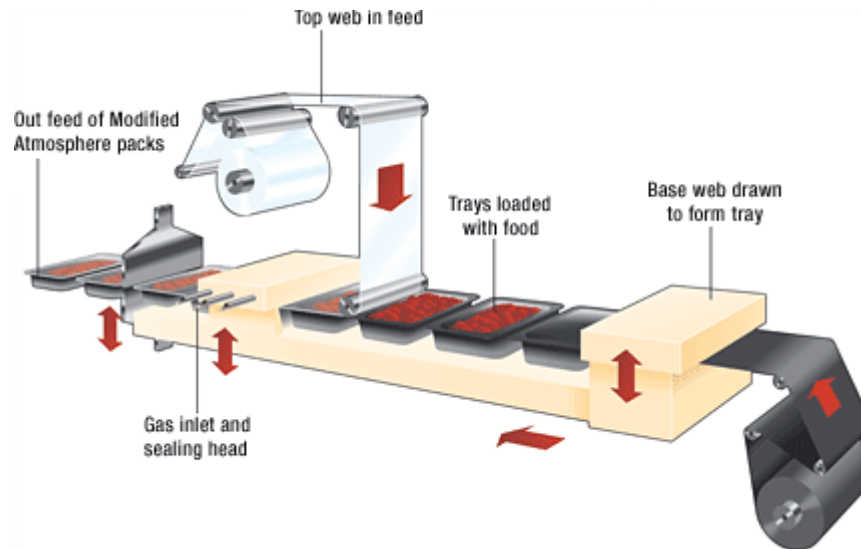
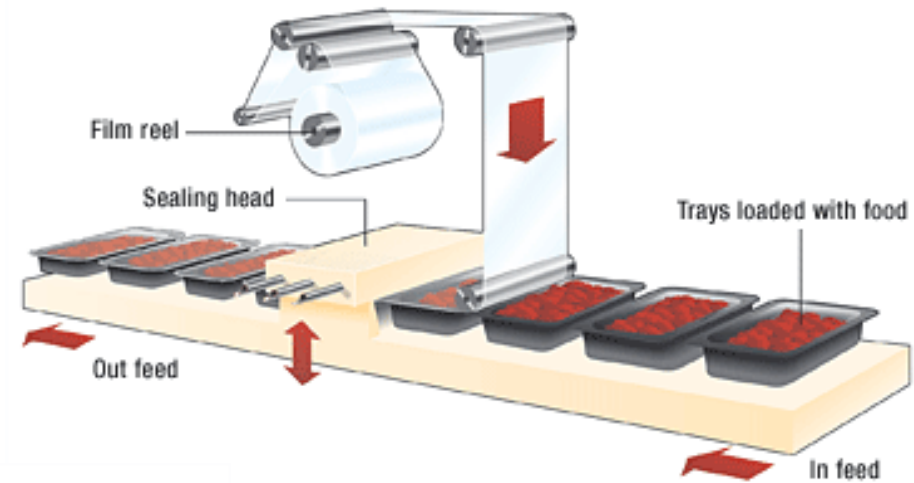



- **MAP in bulk for fresh F&V**

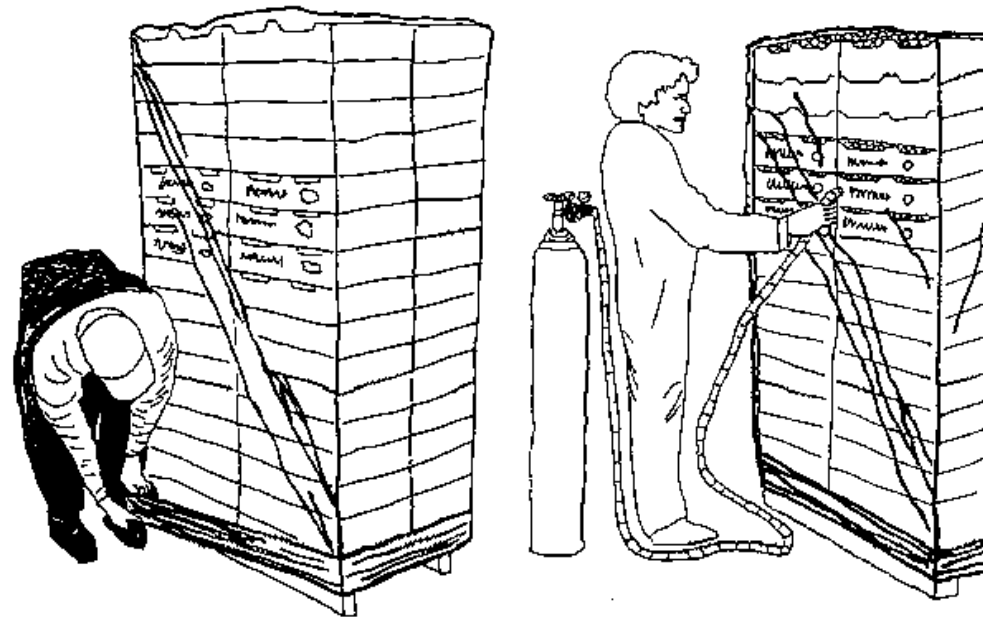



- **Permeability @ 10°C**

	ml μ m/cm ² dayatm		
	PO ₂	PCO ₂	β
PB	68.2	603	8.8
LLDPE	15.7	61.1	3.9
PVC	14.0	85.3	6.1
Ceramic-filled LDPE	12.1	53.8	4.4
EVA	10.1	60.0	5.9
Ceramic-filled PS	7.1	38.4	5.4
LDPE	6.7	22.3	3.3
CPP	3.2	9.2	2.8
OPP	2.1	6.4	3.1
HDPE	0.1	0.6	4.7
PET	0.1	0.4	3.4
Nylon multilayer	0.1	0.4	3.5
PVDC	2.8E-3	2.8-2	10.2
Silicon rubber	680	4.3+3	6.4
Perforation (air)	1.5E+8	1.2E+8	0.8
Microporous film	2.3E+6	2.3E+6	1.0



- **Films with permeability and β suitable**
 - New materials: perforated, microporous, etc.
- **Permeability data @ temperature of use**
- **Time for equilibrium**
 - Injection of correct mixture
- **Temperature variations through distribution chain and during storage**
 - Active and intelligent systems



- **Films with improved barrier properties**
 - E-VA high E content (6-18%)
 - LDPE (Elvax, DuPont),
 - S-B block copolymer films (K-Resin, Chevron Phillips Chemical)
 - ULDPE (ethylene-octene) copolymer films (Attane series, Dow Chemical)
 - Polyolefin plastomer octene copolymer films (Affinity series, Dow Chemical)
 - OPP laminates (BP Amoco)



- **Laser microperforated film**
 - **Permeability depends:**
 - **Diameter and number of perforations (< 150 μm)**
- **Example:**
 - **Amcor**





- **Microporous films**
 - **Films extrusion with mineral fillers**
 - CaCO_2 , SiO_2
 - **Permeability: amount of filler, particle size and film stretching degree**
- **Exemple:**
 - **Fresh Hold (River Ranch, Inc.)**





- **Ethylene absorbers**
- **Antimicrobial materials**
- **Oxygen emitter/carbon diox. Absorber**
- **TTIs**
- **Breathable materials**
- **Volatiles indicators**
- **RFID labels**





Ethylene Control, Inc.



Peak Fresh®



Ethylene Control, Inc.



Bio Fresh™

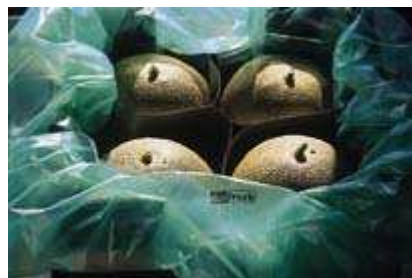

Delta Trak



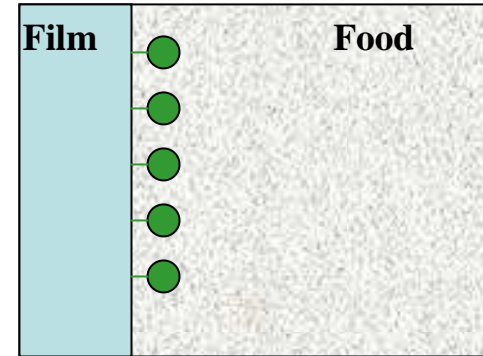
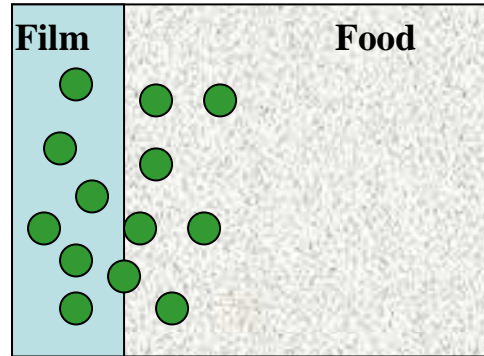

- **Avery-Dennison's label**
 - Releases ClO_2





- **OxyFresh (EMCO Fresh Technologies Ltd)**



- **Used by Monoprix since 90`s**
 - **Fresh-Check®** in individual packages
 - **400 own-brand products**
- **Carrefour since 2005 in on-line sells**





- **Monitoring Q**

$$-\frac{dQ}{dt} = kQ$$

$$K = K_0 \exp\left[\frac{-E_Q}{R} \left(\frac{1}{T} - \frac{1}{T_0}\right)\right]$$

- **Visible response X**

$$X = f(t)$$

$$F(X) = K_{TI} t$$

$$\frac{dF(x)}{dt} = K_{TI}$$

$$\frac{dF(x)}{dt} = K_{TI0} \exp\left[\frac{-E_{TI}}{R} \left(\frac{1}{T} - \frac{1}{T_0}\right)\right]$$

Selection of TTI should consider the “match” between E_Q and E_{TI}



Product	Q	Ea (KJ/mol)
Cut carrot	Respiration rate	79
Mushrooms	Colour change	63
Strawberry	Firmness	39

TTI	Mechanism	Ea (KJ/mol)
Monitor Mark®	Diffusion	33-35
Check point®	Enzymatic	50-113
Fresh-Check®	Polymerization	84-100



• Fresh-Check



Fresh-Check® Indicator

- FRESH
- STILL FRESH
- STILL FRESH CONSUME IMMEDIATELY
- FRESHNESS NO LONGER GUARANTEED IF CENTER IS DARKER THAN RING.

Color of center shows remaining shelf life.

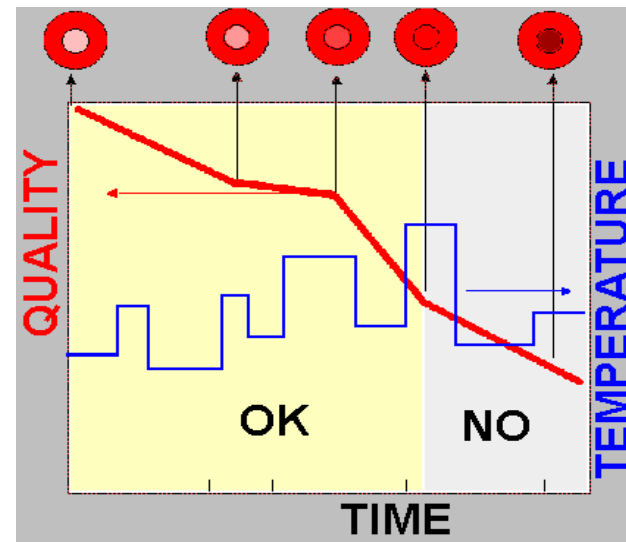

- **Materials with permeability responding to changes in temperature**

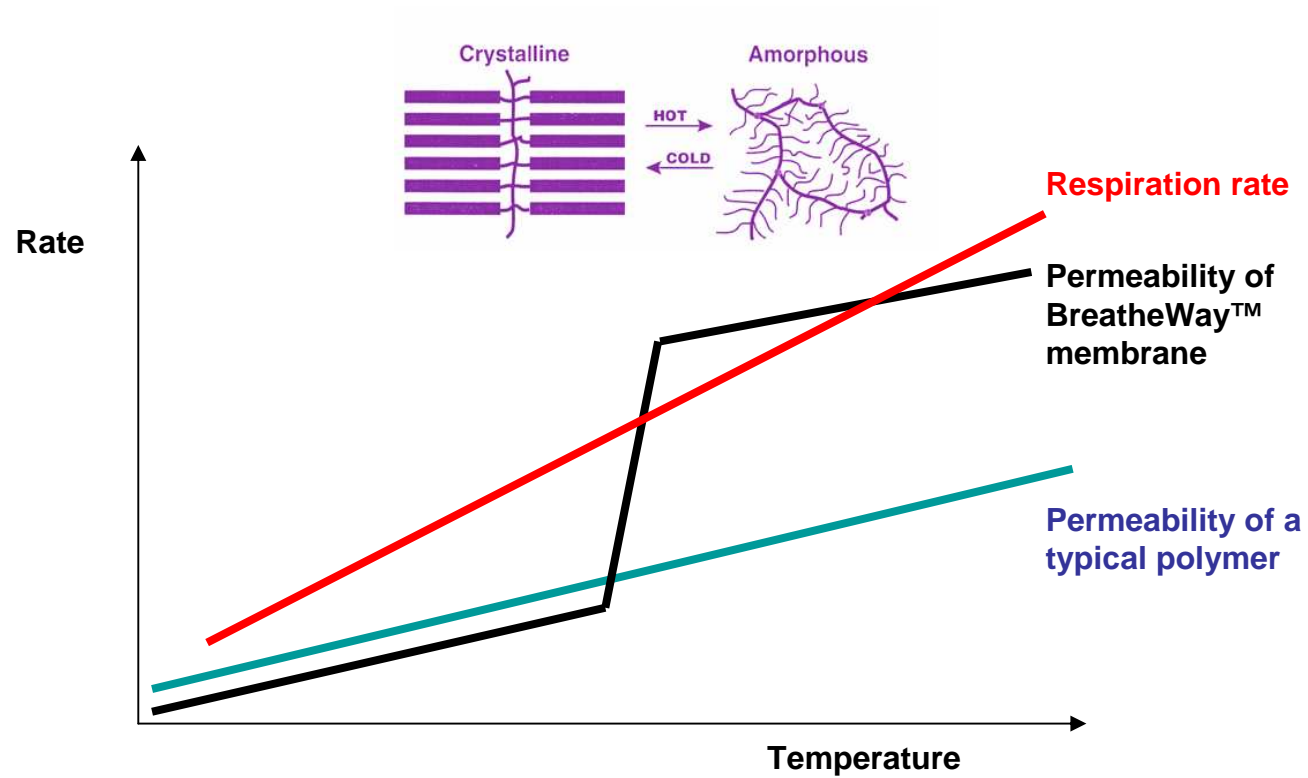



System BreatheWay™

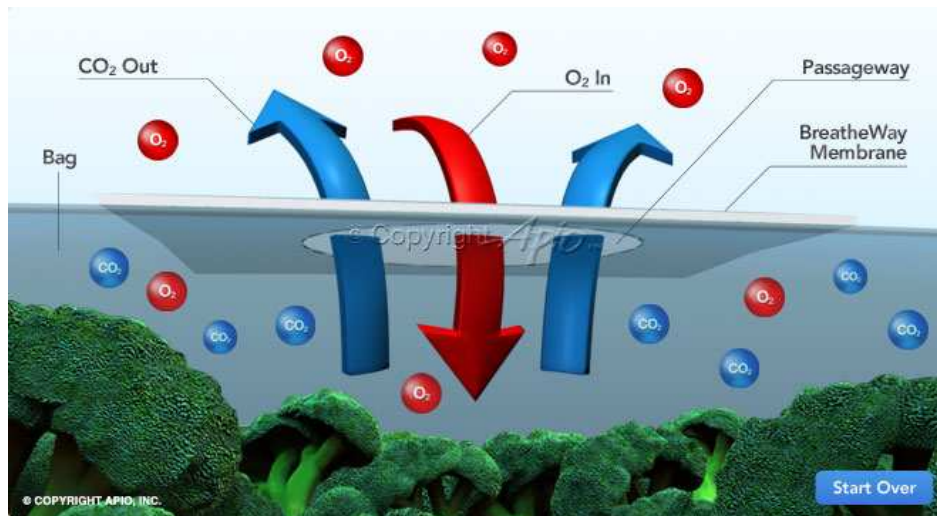

- **Indicador RipeSense® (Jenkins Group)**

